

Canoe & Kayak

Garage

STORAGE



ONE-PERSON OPERATION

Raises and lowers easily with a single control rope

EASY TO INSTALL

Kit comes complete

SAFE, SELF-LOCKING

Safety cleat grips instantly if rope is accidentally released

LIFTS EVENLY

From 10 to 200 lbs

MAXIMIZE GARAGE SPACE

STORE AT CEILING LEVEL

One person can easily raise and lower with a single control rope.



Three styles store everything from canoes and kayaks to bikes, ladders and roof racks.

(45, 60, 90, 145, 200 lbs)
WE STORE IT ALL!

EASY TO USE

EASY TO INSTALL

COMPLETE KIT

SELF-LOCKING



Web: www.hoister.com Tel: 262-691-3320



AFTER



BEFORE

3-Easy Steps

1 Secure



Maximize garage space by storing items up and out of the way. This block-and-tackle system allows one person to easily raise and lower items with a single rope. A self-locking pulley grips instantly even if the rope is accidentally released.

Tools/Supplies needed (purchase separately): Drill; Stud finder; Drill bits: 3/32" (2.5 mm), 7/32" (6 mm); Stepladder; Safety glasses, Tape measure; One 2" x 6" x 6' (50 mm x 152 mm x 1.83 m) grade 2 or better pine board

Part No.	Description	Mechanical advantage	Max vertical lift		Max item width		Lifting weight			
			ft	m	ft	m	Min	Max	lb	kg
7800	Bike/Utility Lift	2:1	8	2.4	5	1.52	10	4.5	45	20
7801	4-Point storage system	3:1	8.5	2.6	5	1.52	15	7	60	27
7802	4-Point storage system	4:1	8.5	2.6	5	1.52	25	11	90	41
7803	4-Point storage system	6:1	8.5	2.6	5	1.52	45	20	145	66
7806	4-Point storage system	8:1	8.5	2.6	5	1.52	75	34	200	91
7807*	2-Point storage system	3:1	8.5	2.6	5	1.52	15	7	60	27

*This System

4977/06-11 Printed in USA

3 Store



Includes all mounting hardware

2 Lift



2-POINT LIFT SYSTEM
#7807 Maximum Load:
60 lbs (27 kg)

WARNING! Strictly follow all instructions to avoid an accident, damage to property, personal injury or death. See www.harken.com for additional safety information.

SAVE TIME! READ THE ENTIRE MANUAL BEFORE BEGINNING HOISTER INSTALLATION.

INSTRUCTIONS

Kit Includes:

Parts Included:

- 2 Harken Micro pulleys..... A
- 1 Harken organizer..... B
- 2 #10 x 2 1/2" (6 x 63 mm) screws..... C
- 1 Shackle..... D
- 1 Welded screw eye..... E
- 1 Harken block and tackle..... F
- 2 Drop ropes: 1 long, 1 short..... G
- 1 Single hoisting rope..... H
- 2 7' (2.13 m) webbing straps w/buckles..... I
- 2 Pigtail lag screws..... J
- 4 5/16" x 4" (8 x 100 mm) lag bolts..... K
- 4 Washers..... L

Purchase Separately:

- 1 2" x 6" x 6' (50 mm x 152 mm x 1.83 m), grade 2 or better pine board
- Tools Needed:**
- Electric/hand drill
- Drill bits: 3/32" (4 mm), 7/32" (6 mm), 5/16" (8 mm)
- Stud finder (available at building supply store)
- Stepladder / Safety glasses / Pencil
- Tape measure

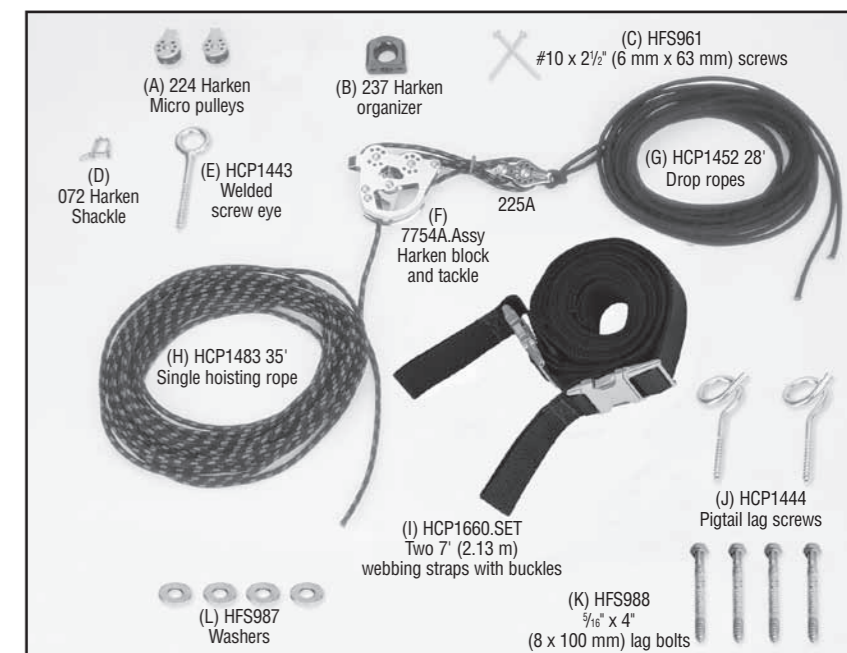

Plan Location of 2-Point Lift System

Read instructions before starting. Plan ceiling location of mounting board. Position welded screw eye (E) at top of adjoining wall. Distance from organizer (B) on end of board to welded screw eye must be equal or greater than lifting distance. See Figure 2 and "Install Welded Screw Eye" instructions next page.

Mount Board to Ceiling

Draw a centerline the length of a 6' (1.83 m) 2" x 6" pine mounting board. Use a stud finder to locate ceiling trusses/rafters on which to mount system (follow manufacturer's instructions). Drill four (three minimum) 5/16" (8 mm) evenly-spaced clearance holes on board centerline matching truss/rafter locations. Use holes in mounting board as template to mark ceiling. Drill truss/rafters using a 7/32" (5.5 mm) drill bit. Install board using 5/16" x 4" (8 x 100 mm) lag bolts (K) with flat washers (L). Do not over-tighten.

IMPORTANT SAFETY INFORMATION

- **DO NOT UNTIE ANY ROPES**
System comes ready to install. Leave F, G and H together.
- **DO NOT RAISE OR LOWER HOISTER**
with anyone standing under object.
- **SECURELY ANCHOR EACH**
fastener to a truss/rafter.

WARNING: Do not screw into laminated rafters. They are not intended to accept fasteners. Consult rafter maker for recommendations. Screwing into laminated rafters may considerably weaken system, causing load to fall which may cause an accident, damage to property, personal injury or death.

WARNING: Do not over-tighten Pigtail Lag Screw past top thread. This can weaken fastener hold which may considerably weaken system, causing load to fall which may cause an accident, damage to property, personal injury or death.

Install Pigtail Lag Screws on 2 x 6 Board

Mark location of two pigtail screws (J) on mounting board centerline.

- Pigtail screws can be 1' (30 cm) to 5' (152 cm) apart depending on width of item lifted.
- Position screws minimum of 6" (152 mm) from end of 2 x 6 board.

Drill two 7/32" (5.5 mm) holes on center, and thread in pigtail screws.

See Figure 1.

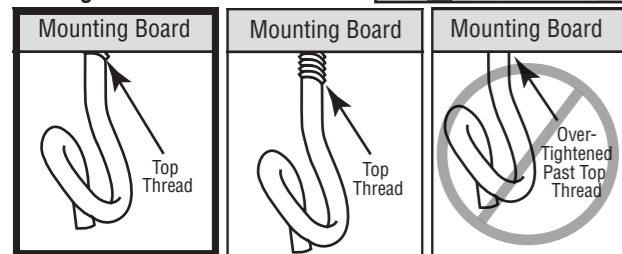

Threads should just disappear into mounting board.

WARNING: Do not over-tighten Pigtail Lag Screw past top thread. This can weaken fastener hold which may considerably weaken system, causing load to fall which may cause an accident, damage to property, personal injury or death.

Install Organizer on 2 x 6

Mark organizer (B) location. Install:

- On the end of the board toward welded screw eye.
- 1/2" (12 mm) to 3/4" (19 mm) off the centerline of the 2 x 6, so lines clear pigtail screws
- 5" (127 mm) or more outside the pigtail screw.

Drill 3/32" (2.5 mm) holes and mount organizer. See figure 1.



Install Welded Screw Eye

Locate welded screw eye (E) in wood top plate running across top of wall. Distance from welded screw eye (E) to organizer (B) must be equal or greater than lifting distance. To gain distance, move welded screw eye laterally. Keep angle at 45 degrees or less. Use a stud finder to find solid wood (follow manufacturer's instructions). Drill a 7/32" (5.5 mm) hole and thread eye into place. See figure 2.

Attach Block and Tackle to Screw Eye

Disassemble shackle (D) and slip "U" shaped strap onto welded screw eye (E). Orient block so cleat faces down, insert shackle pin and secure with ring.

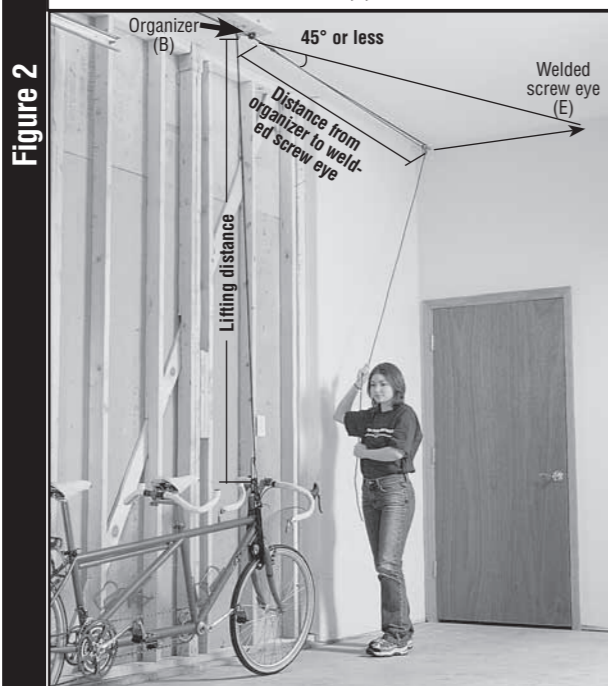
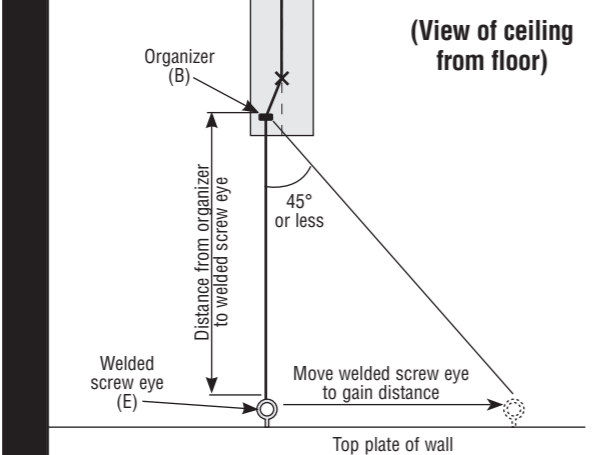
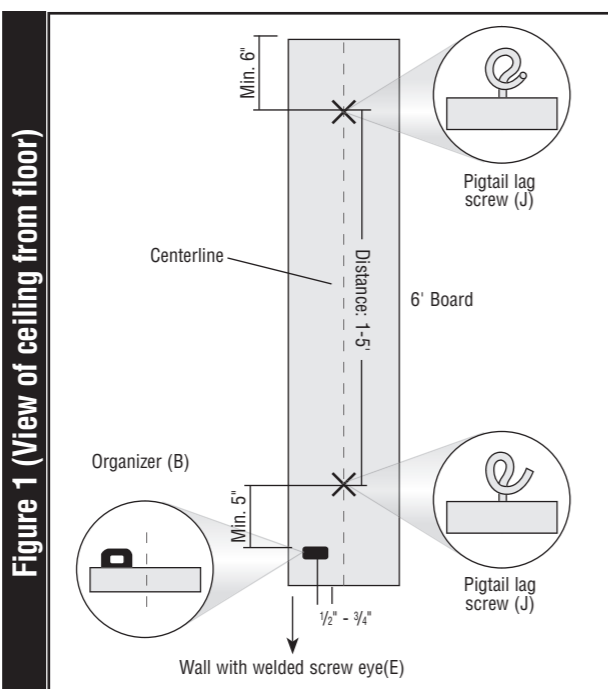

Weave Rope

Place one Micro pulley (A) on each pigtail lag screw (J). Feed drop ropes (G) through organizer (B). Feed short drop rope through near pulley. Feed long drop rope through far pulley. Make sure ropes do not rub on near pulley or pigtail screw.

Align screw eyes in same direction as rope running through pulley. See figure 3

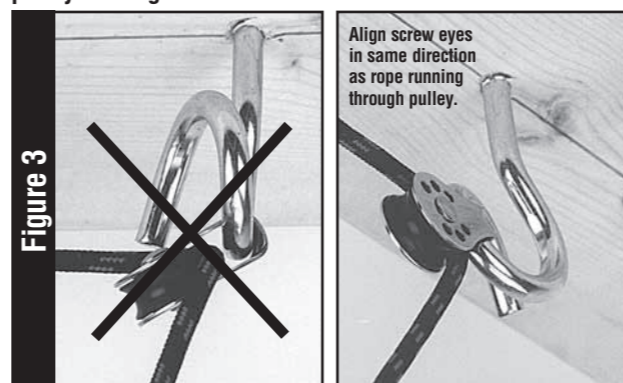

Set Up System

Place object to be lifted in its normal position directly under system.

Tie rope to webbing strap (I) using a "figure 8" knot. See Figure 4.

Tip: Both knots should be close to level to lift object evenly. Check knots. Make sure they are tied securely and will not come undone.

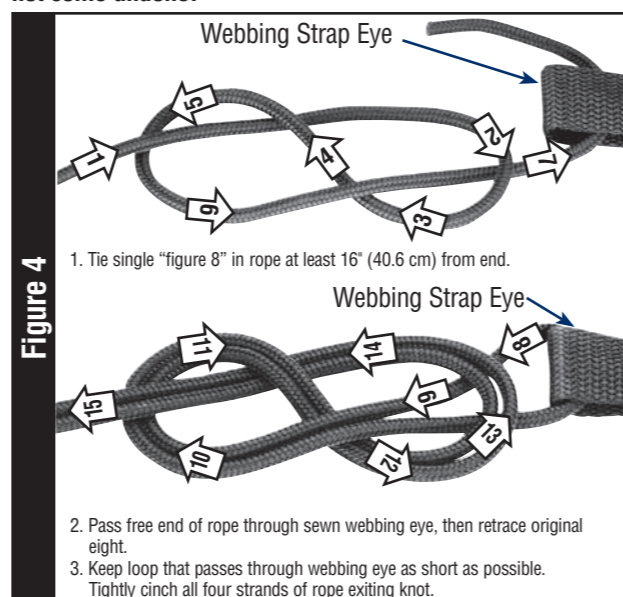

With object to be lifted directly under the system, unbuckle strap assembly. For bikes, thread one buckle through the rear wheel and around the frame, and fasten. Next, thread the other buckle through the front wheel, behind the fork and around the frame, and fasten (see top photo). For other objects, thread buckles around and/or through a solid connection point on the object (ie. the rungs of a ladder or support braces of a wheelbarrow). Then fasten buckles (see bottom photo). You will hear a click when the buckles lock. Adjust straps as needed to balance load.

Equalize Rope Tension

Slowly pull single rope to check if load is level. Both drop ropes must have equal tension so load remains level.

Equalize Rope Tension (Continued)

To level load, adjust tension by moving knot or adjusting webbing strap at buckle. When level/balanced you are ready to lift.

Operate System

Important: for safety, do not raise or lower load with anyone standing under item.

WARNING: When operating system, make sure area below object is clear of persons. If object comes down too quickly this may cause an accident, damage to property, personal injury or death.

CAUTION: Avoid injury, do not let rope slip through hands. Angle line to wall to lock rope.



WARNING: Hang coiled rope where it will not accidentally snag on persons or vehicle. Keep coiled rope out of reach of children. Damage or injury may result if rope is angled away from wall with some tension; the object can come down very quickly which may cause an accident, damage to property, personal injury or death.

A. RAISE OBJECT

Hoist in a series of pulls. Pull Single Black/Red Hoisting Rope (F) straight down.

With rope pointed down cleat will lock rope and you can release it. Repeat until object is at desired height



With rope pointed down the cleat will lock the rope and you can release it. Repeat until object is at desired height.

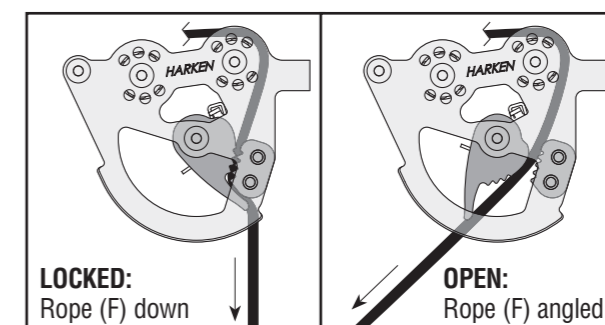

DIAGRAM 21. Locked (left): Single Black/Red Hoisting Rope (F) pointed straight down locks cleat. Open (right): Angled rope opens cleat.

WARNING: Stop pulling as soon as object contacts ceiling or webbing strap knots stop at pulley (D). Damage or injury may result from forcing the system. If in doubt, stop hoisting, allow cleat to lock by angling line down. Stand back to see if object is raised to the maximum or if something is jamming rope or object.

B. STORE OBJECT

With object in raised position make sure Single Black/Red Hoisting Rope (F) is securely locked in cleat with rope pointed down (see Diagram 21). Coil loose rope end. Hang coiled rope for storage when system is not in use.

Tip: For additional security, use two safety 5/16" (8 mm) polyester ropes. Securely tie ends to pigtail lag screws under object, parallel with Webbing Straps (E). Remove safety ropes before lowering object.

C. LOWER OBJECT

Securely grip rope, apply tension and angle it away from front wall. Bring arm up to let rope out and then back towards wall to lock rope. Repeat until object is at desired height.

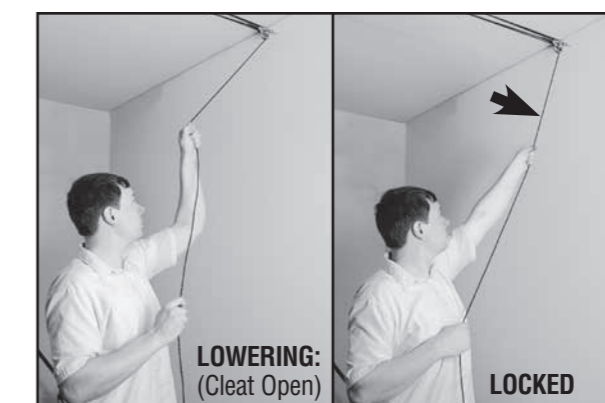

WARNING: When operating system, make sure area below object is clear of persons. If object comes down too quickly this may cause an accident, damage to property, personal injury or death.

CAUTION: Avoid injury, do not let rope slip through hands. Angle line to wall to lock rope.

Tip: Use gloves to protect hands.

D. OPERATION

Attach Bike/Other Items: Place item directly under lifting system and unbuckle strap assembly.

Bicycles: Thread one buckle through rear wheel and frame or rack and fasten. Thread other buckle through front wheel (behind fork), and around frame and fasten.



MAINTENANCE

Inspect rope (H and F), knots and straps regularly for signs of chafe, wearing or UV damage. Replace immediately. Inspect knots for signs of slipping. When attaching object, inspect webbing strap buckles (E) to make sure spring clip functions properly. Replace rope and hardware with Harken parts only.

WARRANTY

What Is Covered – This warranty covers defects in materials or workmanship.

Who Is Covered – The original purchaser.

For How Long – Harken® products are warranted for five (5) years from the date of purchase:

After the end of any specific warranty period noted above, HARKEN® MAKES NO EXPRESS OR IMPLIED WARRANTIES OF ANY KIND WITH RESPECT TO THE PRODUCTS, INCLUDING ANY WARRANTY OF MERCHANTABILITY OR FITNESS FOR A PARTICULAR PURPOSE. Some states, or if you live outside the U.S., some countries, do not allow limitations on how long an implied warranty lasts, so above limitation may not apply to you.

What Is Not Covered – This warranty does not cover any product that was: improperly installed; inadequately inspected after installation; improperly maintained; used in any application for which it was not intended; used under load conditions exceeding the rating or other recommendation published in the Harken® catalog; or subject to misuse, negligence, accident, or unauthorized modification or repair. Ropes, buckles and webbing are also not covered. Labor charges are also not covered. Separate warranty provisions may be available from vendors on some of the above products. Contact Harken® for this warranty information.

CONSEQUENTIAL AND INCIDENTAL DAMAGES ARE NOT RECOVERABLE UNDER THIS WARRANTY. Some states do not allow the exclusion or limitation of incidental damages, so above limitation or exclusion may not apply to you.

How To Get Service – If something goes wrong, contact Harken® directly or your local Harken® dealer to arrange for warranty assistance. Your dealer has Harken® Warranty Return Guidelines that provide you with exact return procedures depending on product involved. We will need, in writing, your name, address, phone number, date of purchase, product involved, application, an explanation of defect and conditions under which the product was used. We are fair and we do care when Harken® products do not perform.